

STABILA®



How true pro's measure

TECH 196 TECH 196 M

User manual



Contents

Section	Page
• 1. Intended use	3
• 2. Safety information	3
• 3. Components of the unit	4
• 4. Display elements	5
• 5. Commissioning	6
• 5.1 Inserting batteries/battery replacement	6
• 5.2 Switching the unit on	6
• 6. Functions	7
• 6.1 Visual guidance	7
• 6.2 Acoustic guidance	8
• 6.3 Automatic display inversion	8
• 6.4 Setting the MODE unit of measurement	9
• 6.5 Locking the measurement with HOLD	9
• 6.6 Freely selectable zero position REF	10
• 6.7 Lighting	11
• 6.8 Key lock	11
• 6.9 Automatic switch-off time: Auto OFF	11
• 7. Tilt function	12
• 8. Checking the measuring tool	13
• 8.1 Accuracy check	13
• 8.3 Adjusting the sensor	15
• 9. Error messages	20
• 10. Technical data	21

1. Intended use

Congratulations on the purchase of your STABILA measuring tool.
The STABILA TECH 196 / 196 M is a digital measuring tool for measuring inclinations.



If you still have questions after reading through the operating instructions, you can obtain advice by telephone:



+49 63 46 3 09 0
1.800.869.7460 U.S. and Canada

Equipment and functions:

- Vertical vial(s) for vertical levelling, in reverse position too
- Horizontal vial for horizontal levelling, in reverse position too
- Electronic module with 2 digital displays for accurately determining inclinations and angles
- TECH 196 M: Extra-strong rare-earth magnets

2. Safety information

Read the safety instructions and operating instructions through carefully.

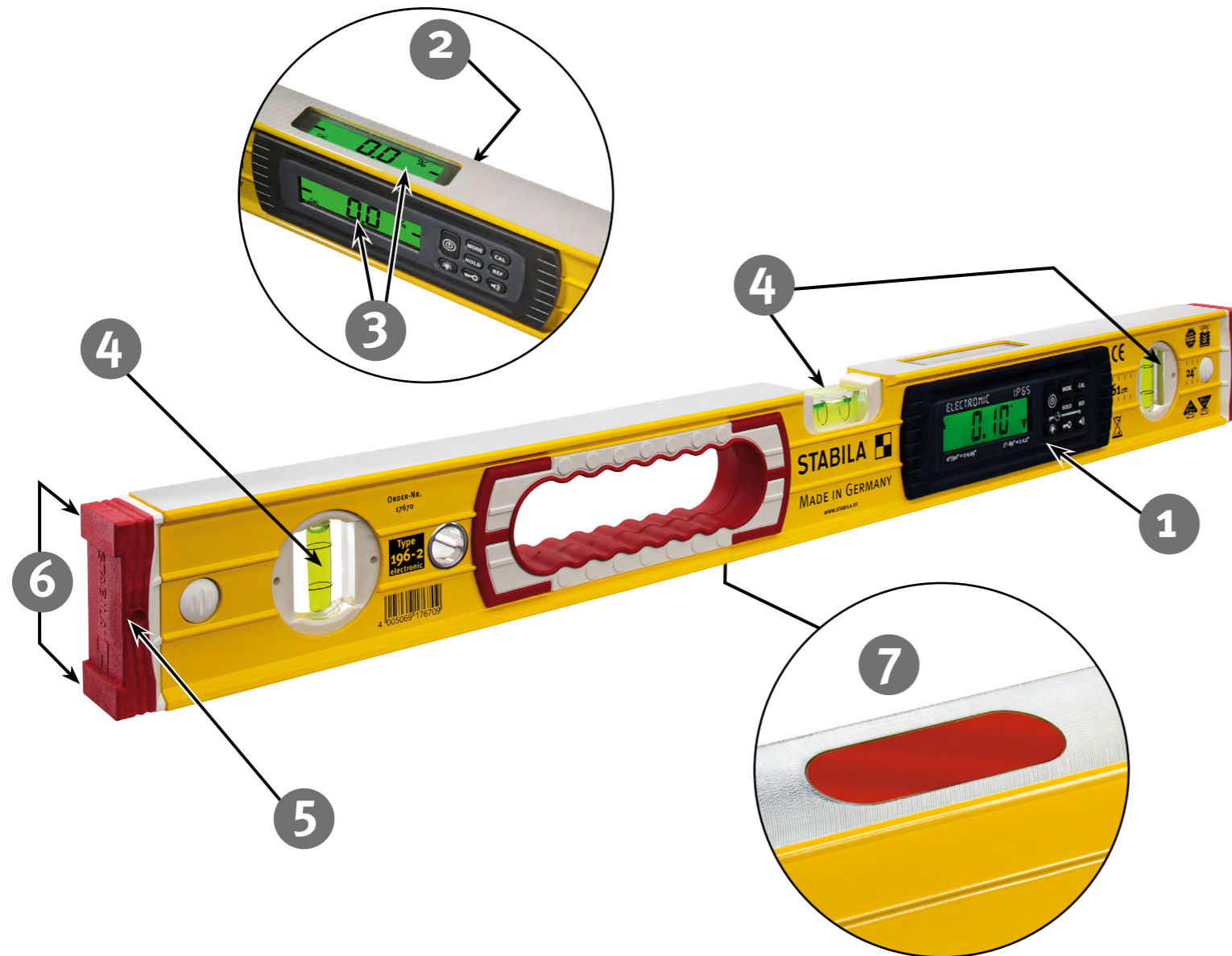

3. Components of the unit

- (1) Electronic module
(dust-proof and waterproof in accordance with IP 65)
- (2) Battery compartment lid
- (3) 2 Displays
- (4) Vials - vertical and horizontal
- (5) Removable, shock-absorbing end caps
- (6) Anti-slip stopper
- (7) Rare-earth magnet (196 M)

Buttons:

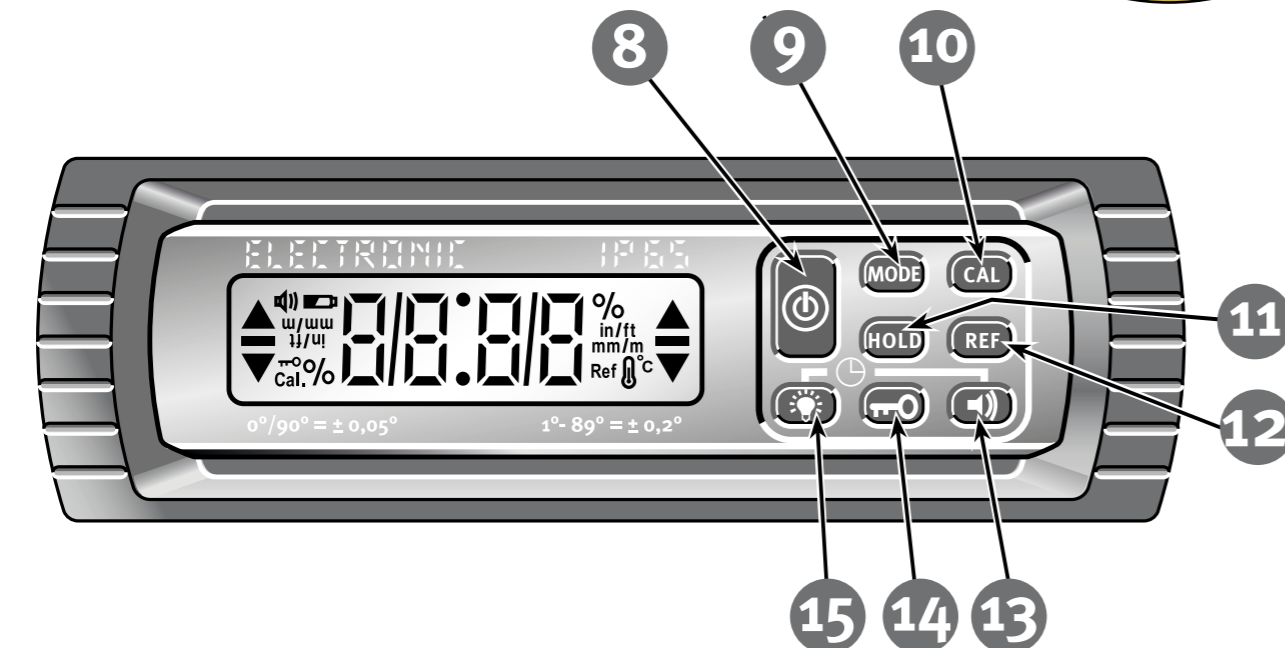

(8) On/Off



(9) Units of measurement: °, %, mm/m, in/ft



(10) Calibration and sensor adjustment



(11) HOLD – locking measurements



(12) Reference – freely selectable zero position



(13) Acoustic guidance



(14) Key lock



(15) Display lighting

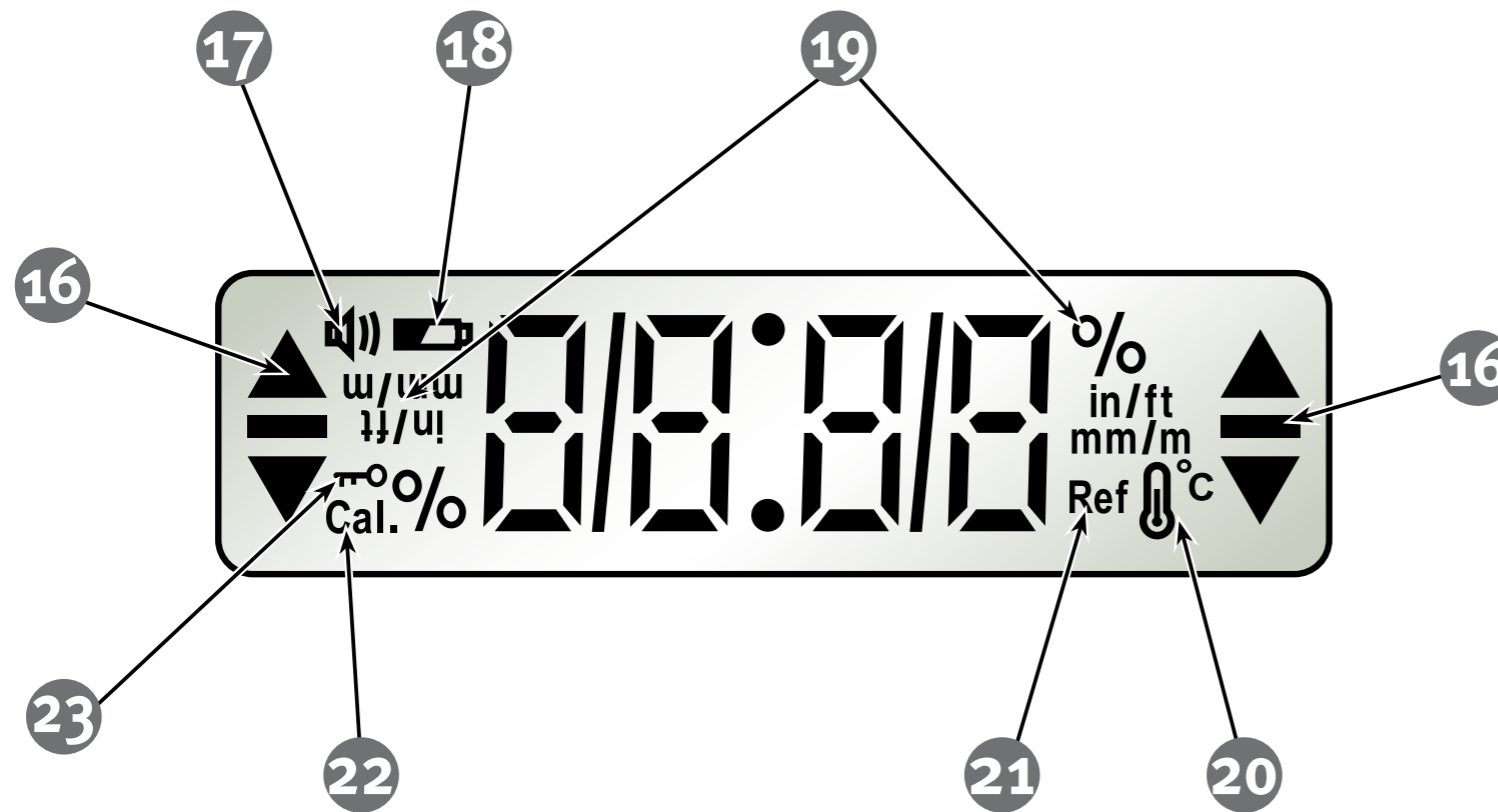

4. Display elements

- (16) Elements for visual guidance
- (17) Acoustic guidance: activated
- (18) Battery low – see chapter 5.1
- (19) Units of measurement: °, %, mm/m, in/ft
- (20) Significant temperature change – see chapter 9
- (21) Reference: activated
- (22) Sensor calibration necessary – see chapter 9
- (23) Key lock: activated

5. Commissioning

5.1 Inserting batteries/battery replacement

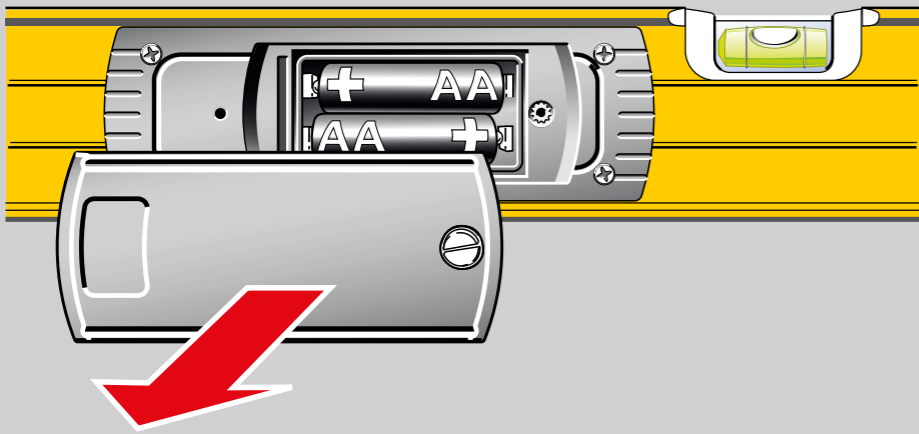
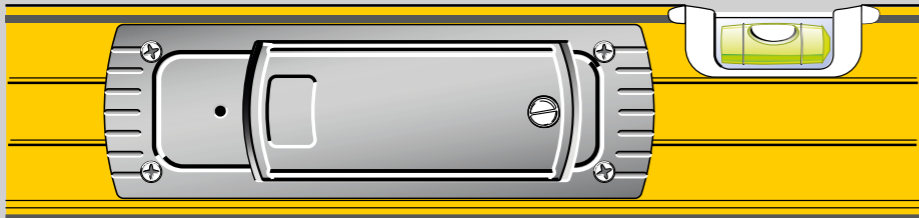

Unscrew battery compartment lid on rear, insert new batteries according to symbol in battery compartment. Suitable rechargeable batteries can also be used.

LCD:
low battery charge - insert new battery



Dispose of used batteries at suitable collection points - not with household waste. Do not leave in unit!

Remove the batteries if you do not intend to use the unit for some time!

5.2 Switching the unit on

After switching on with the "ON/OFF" button, an automatic test is carried out. All the display's segments are shown.

After the end of the test, the version number S x.xx of the software is briefly displayed and the automatic switch-off time (Auto OFF) is shown.

An acoustic signal indicates that the unit is ready for operation. The display shows the angle measured in the set unit of measurement.



Test



Software Version

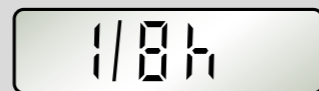

Auto OFF



Speaker icon = OK ✓

6. Functions

6.1 Visual guidance

In the range of $\pm 15^\circ$ to the horizontal (0°) or to the vertical (90°), arrows show which way to turn the digital protractor to reach 0° or 90° .

The 2 "centre display" bars indicate the precise position at which 0° or 90° is reached.

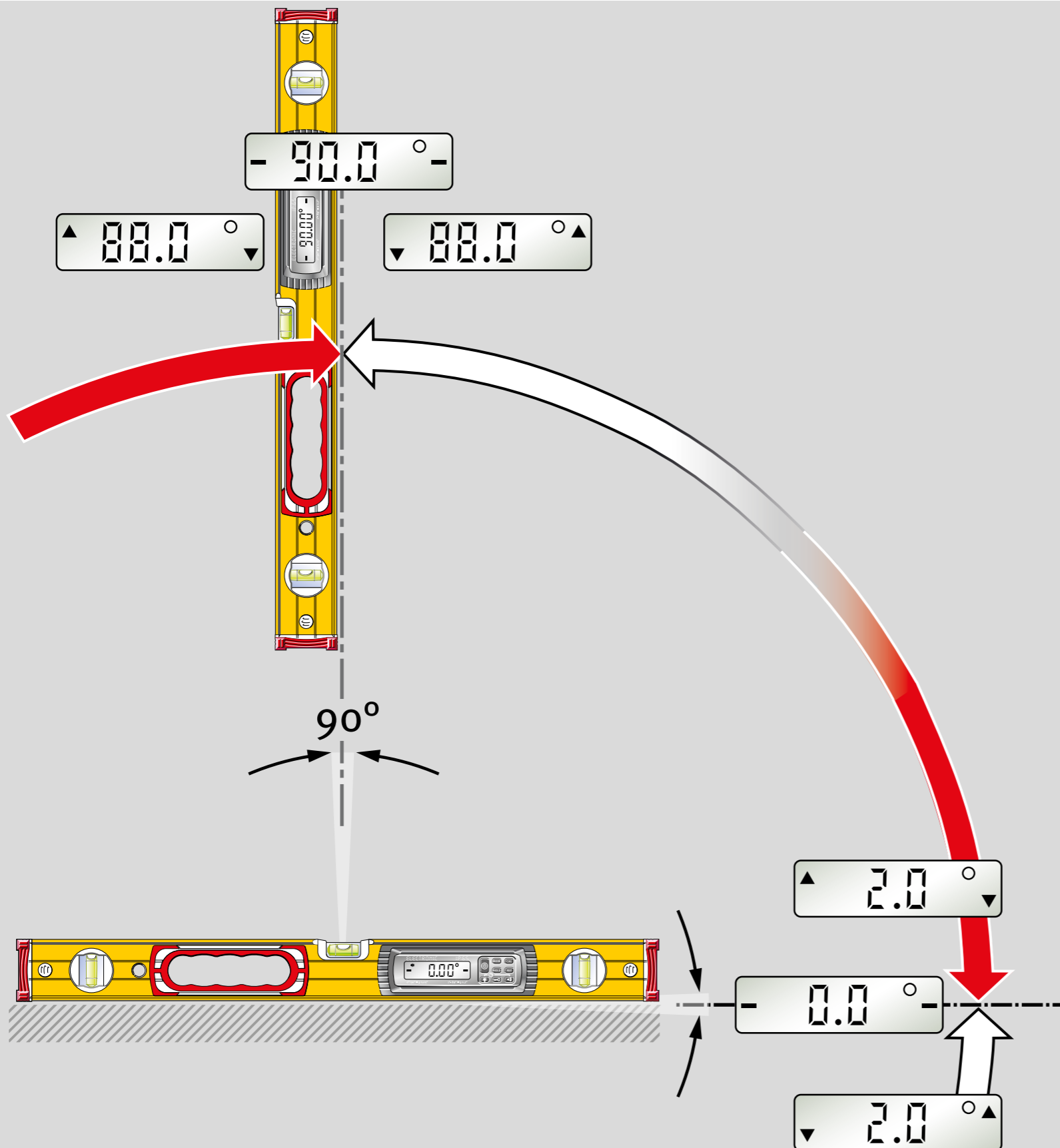

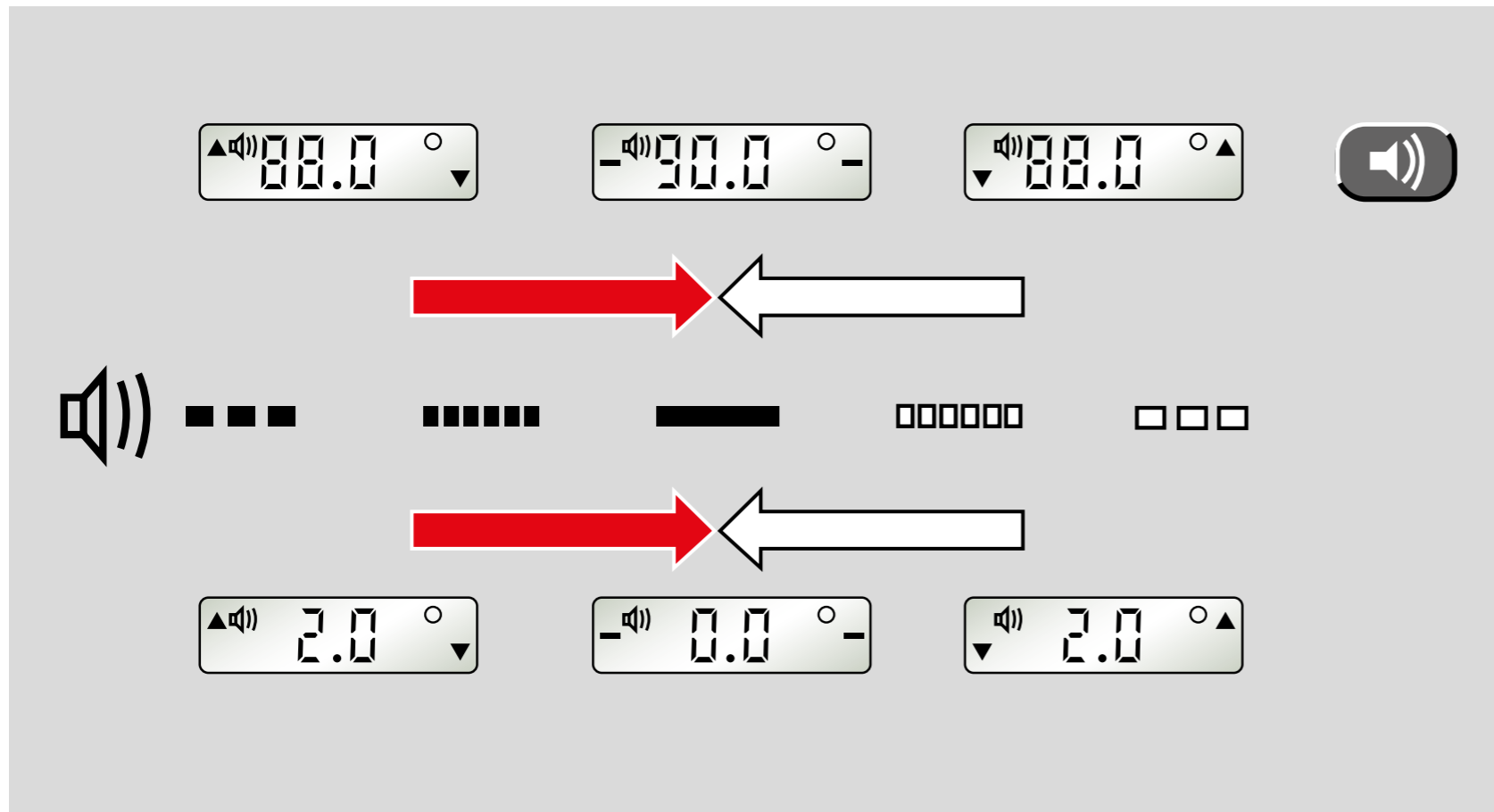

6.2 Acoustic guidance

The acoustic guidance is activated/deactivated using the "Loudspeaker" button. The tone sequence speeds up as the 0° or 90° position is approached in a range of $\pm 2^\circ$. A change in the pitch indicates that these positions have been exceeded.

A continuous tone confirms the precise point at which 0° or 90° is reached.





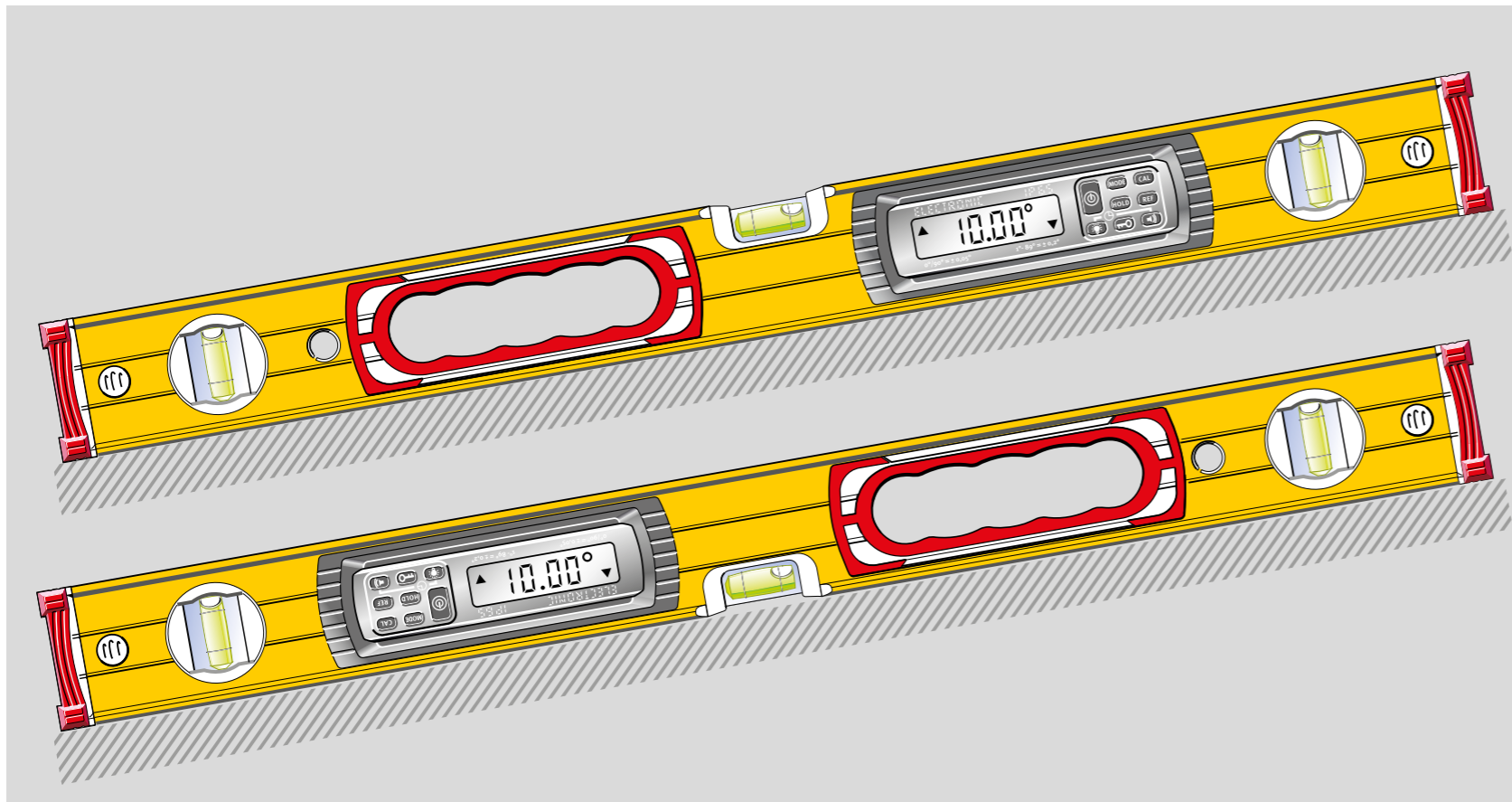

6.3 Automatic display inversion

The display is inverted for overhead measurements so that they are always easy to read.



6.4 Setting the MODE unit of measurement

The unit of measurement is set by pressing the "MODE" button several times.

	° Fine:	Display in 0.01°	steps
	° Rough:	Display in 0.1°	steps
	%:	Display in 0.1 %	steps
	mm/m:	Display in 1 mm/m	steps
	in/ft decimal:	Display in 0.01 in/ft	steps
	in/ft fraction:	Display in 1/8 in/ft	steps

The set unit of measurement is retained after the unit is switched off.

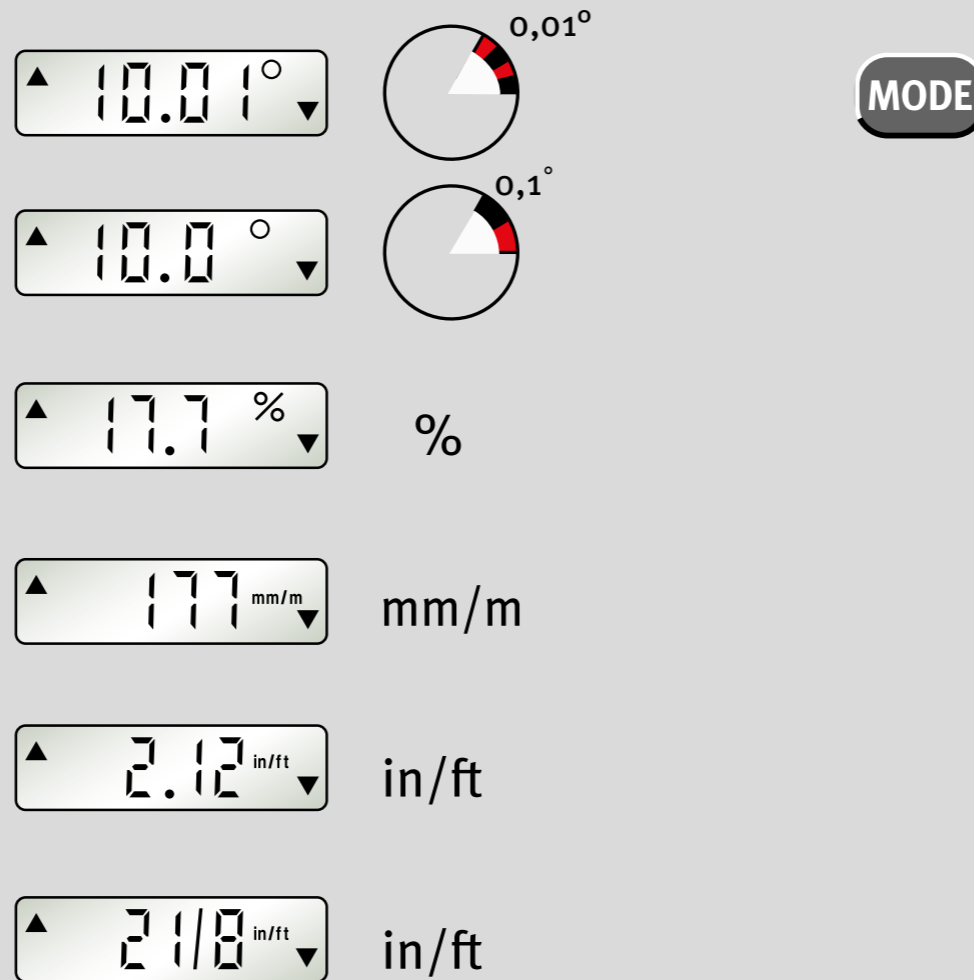

▲ 10.01° ▼

▲ 10.0° ▼

▲ 17.7 % ▼

▲ 177 mm/m ▼

▲ 2.12 in/ft ▼

▲ 2 1/8 in/ft ▼

MODE

6.5 Locking the measurement with HOLD

The current measurement can be locked by pressing the "HOLD" button. The visual guidance indicator flashes. The measurement is displayed continuously. The locked measurement is deleted by pressing the "HOLD" button again or switching the unit off.

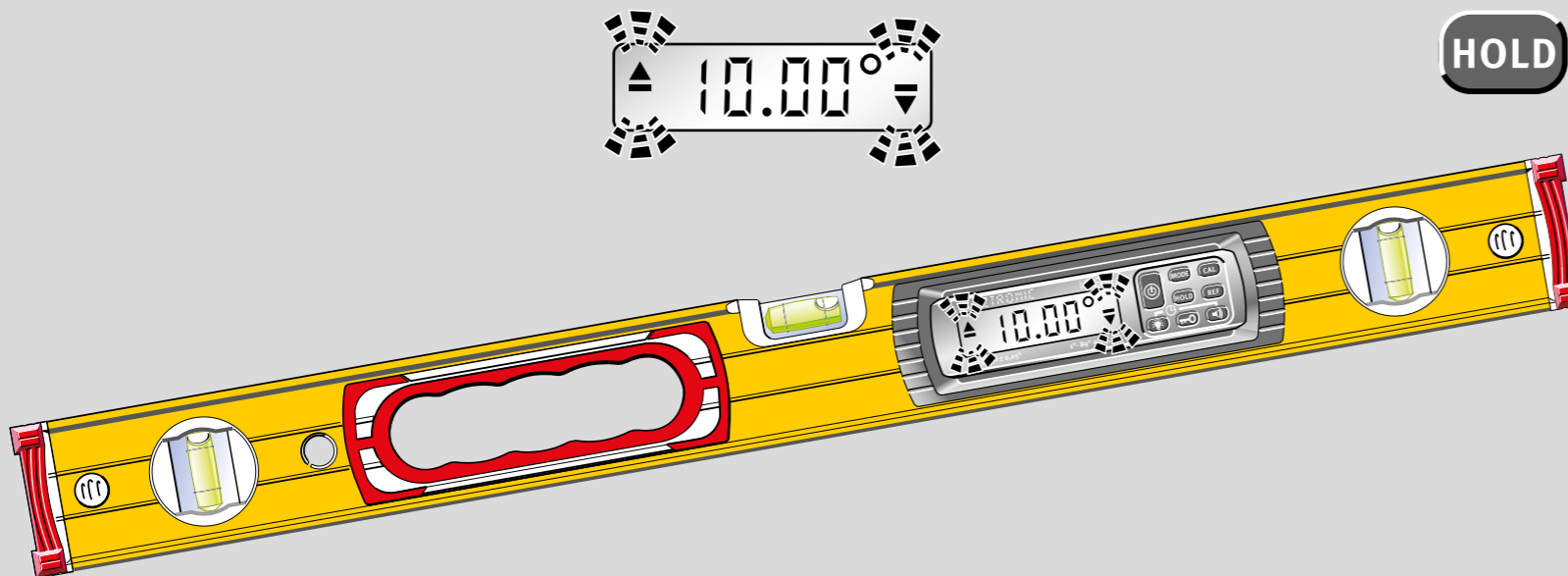

▲ 10.00° ▼

HOLD

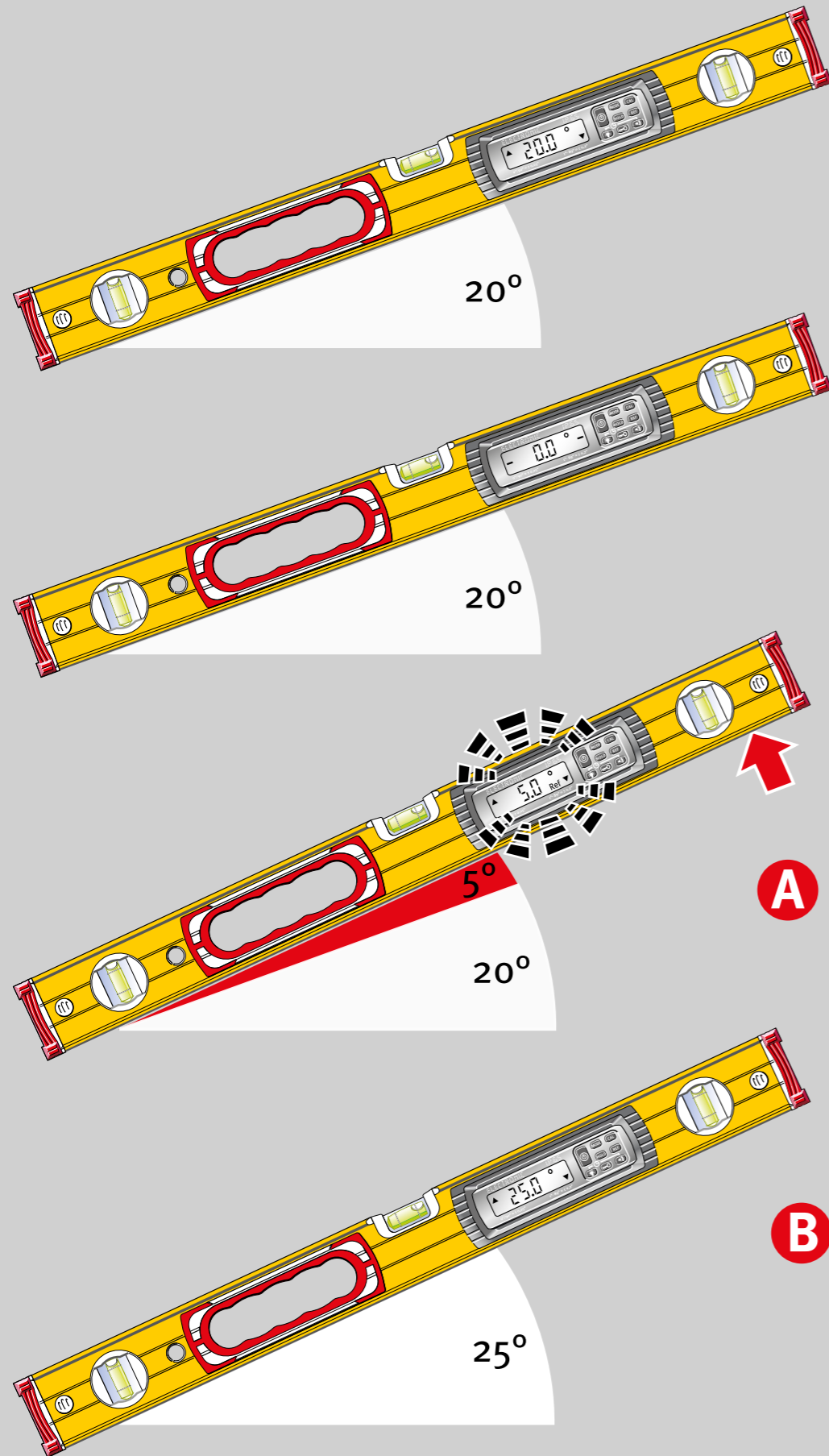

20.0 °

REFERENCE

20°

REF

0.0 Ref

0°
(≅ 20°)

5.0 Ref

+5°
(≅ 25°)

REF

20.0 Ref

20°
(+ 5°)

2 sec

5.0 Ref

REF

3 sec ≥ 3 sec

25.0 °

RESET
REFERENCE

6.6 Freely selectable zero position REF

The "REF" button can be used to select any set angle as 0° reference. The angle details now displayed relate to this reference angle. The displayed value flashes with this setting.

A

The reference angle value is displayed for 2 seconds by briefly pressing the "REF" button.

B

The reference angle is deleted by:

- pressing and holding (≥ 3 sec) the "REF" button. The activated button lock must be released before deleting the angle.
- Switching off
- The automatic switch-off function

The zero position then refers back to the original setting.



The alignment selected for the digital protractor must not be changed during the reference function, as this could lead to a display error.

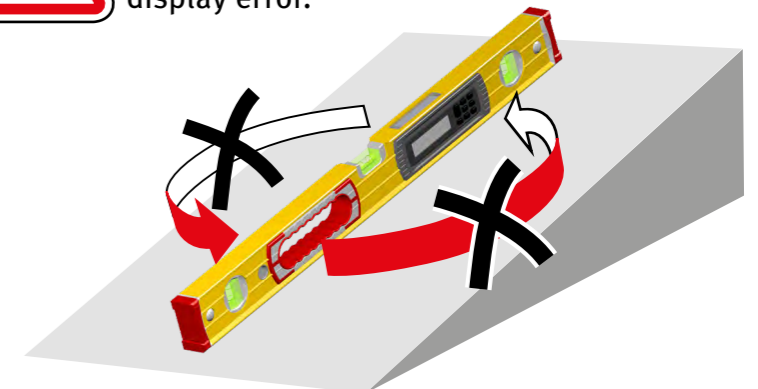

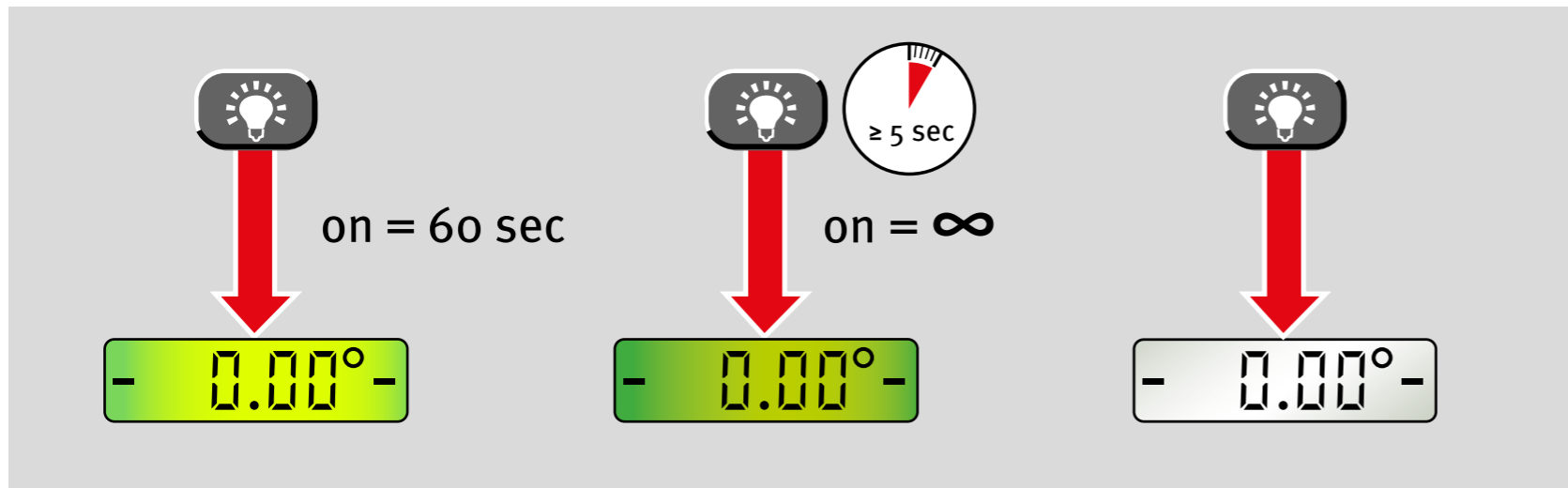

6.7 Lighting

Briefly pressing the "Lighting" button switches the display lighting on for approx. 60 seconds.

Pressing and holding (≥ 5 sec) the "Lighting" button makes the lighting darker and switches it on permanently.

The lighting is switched off by pressing the "Lighting" button again, or by switching off the unit.

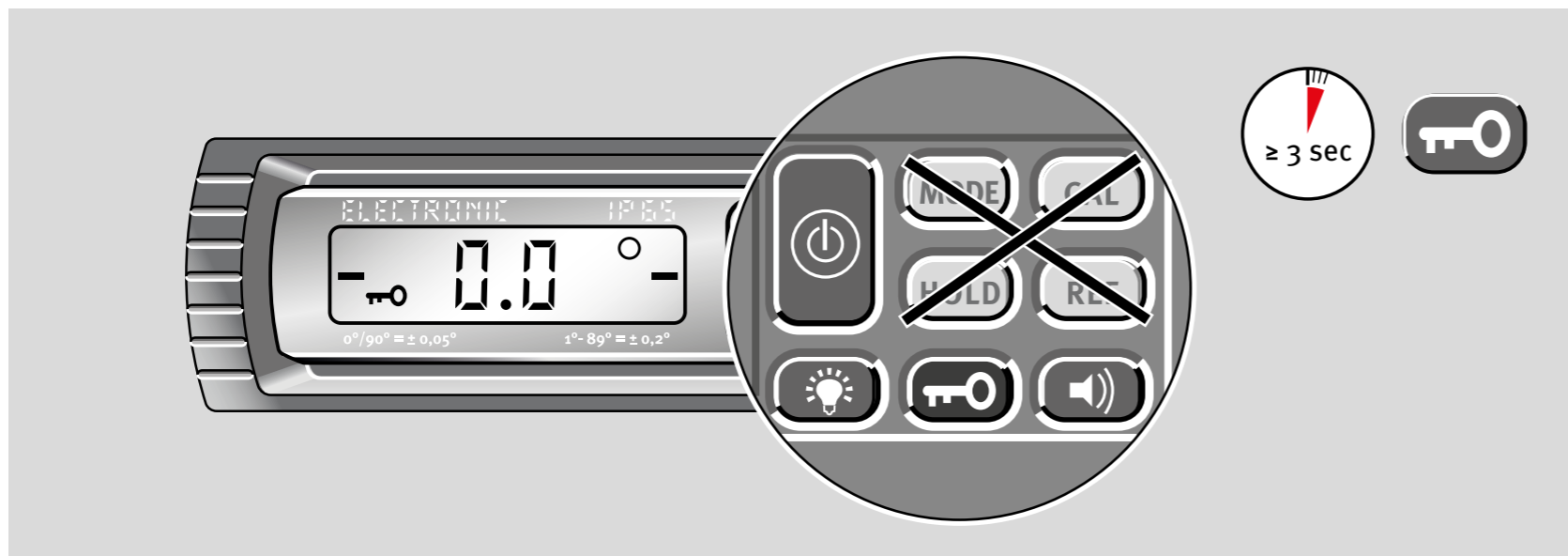

6.8 Key lock

Function: Key lock to prevent inadvertent activation.
Display after activation: key symbol.

The lock is activated for the following buttons:
"MODE, CAL, HOLD, REF"

The key lock remains active after switching the unit off and back on again!
Pressing and holding (≥ 3 sec) the "Key" button disables the key lock.

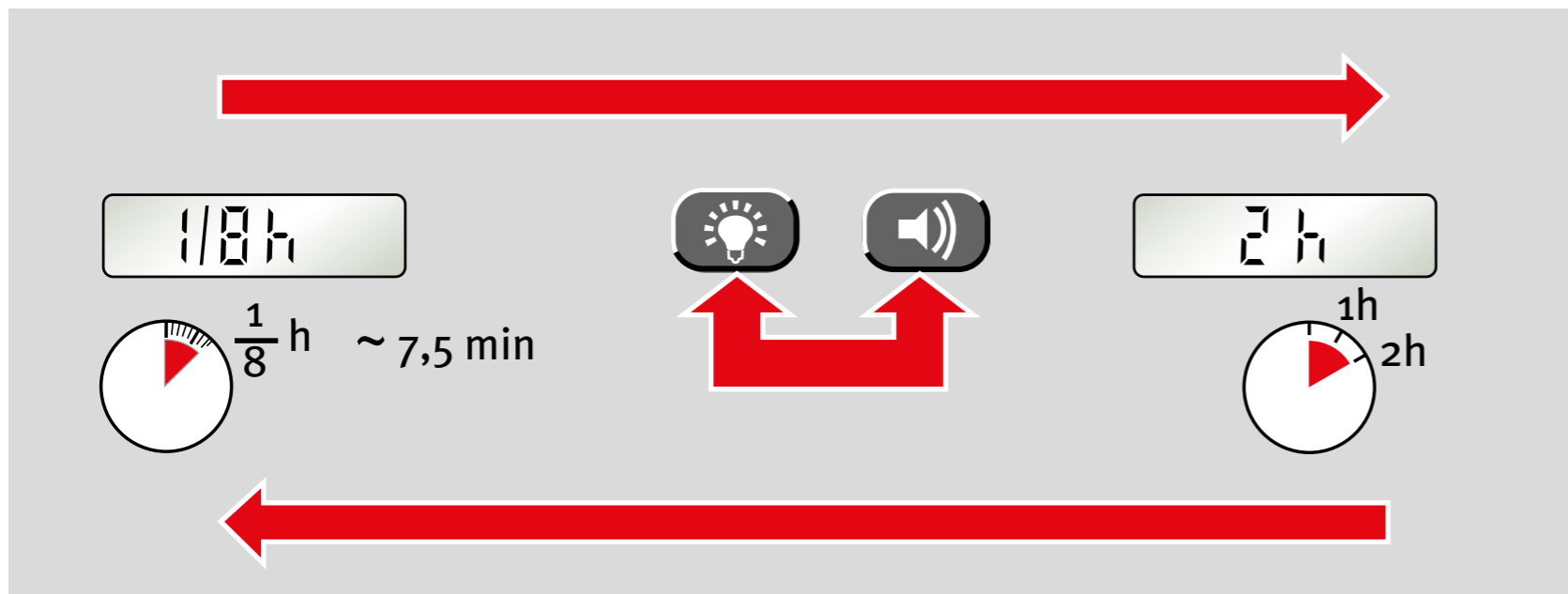

6.9 Automatic switch-off time: Auto OFF

Pressing the "Lighting" and "Acoustic guidance" buttons at the same time allows the automatic switch-off time to be changed from 1/8 of an hour (approx. 7.5 minutes) to 2 hours. The set switch-off time is retained after the unit is switched off and is displayed briefly when it is switched on again.

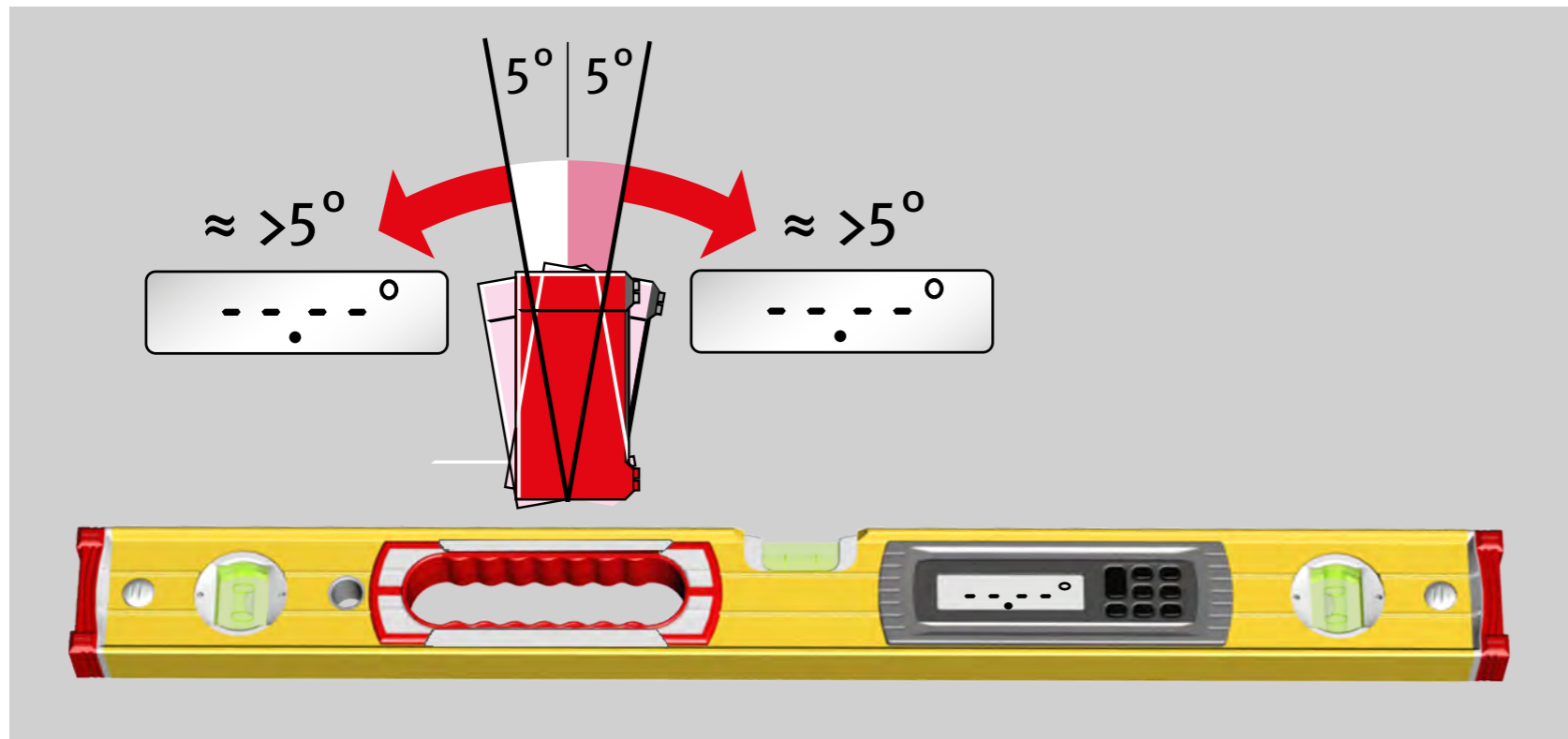

7. Tilt function

The measuring surfaces of the electronic spirit level should be positioned precisely for all measurement work. If positioned at too great an angle, the tilt function prevents incorrect measurements. The display doesn't then show any measurements.

8. Checking the measuring tool

8.1 Accuracy check



To prevent incorrect measurements, the accuracy must be checked at regular intervals, e.g. before you start work, or after hard knocks or major changes in temperature.

Step 1:

Switch on the electronic spirit level. Use the vial to accurately align the unit to a wall, for example, until the vial bubble is in the middle between the vial rings.

Step 2:

Wait 10 seconds. If the value displayed is $> 0.05^\circ$, the electronic spirit level must be recalibrated.

If mainly used for vertical measurements, the accuracy check can also be undertaken with the vertical vial.

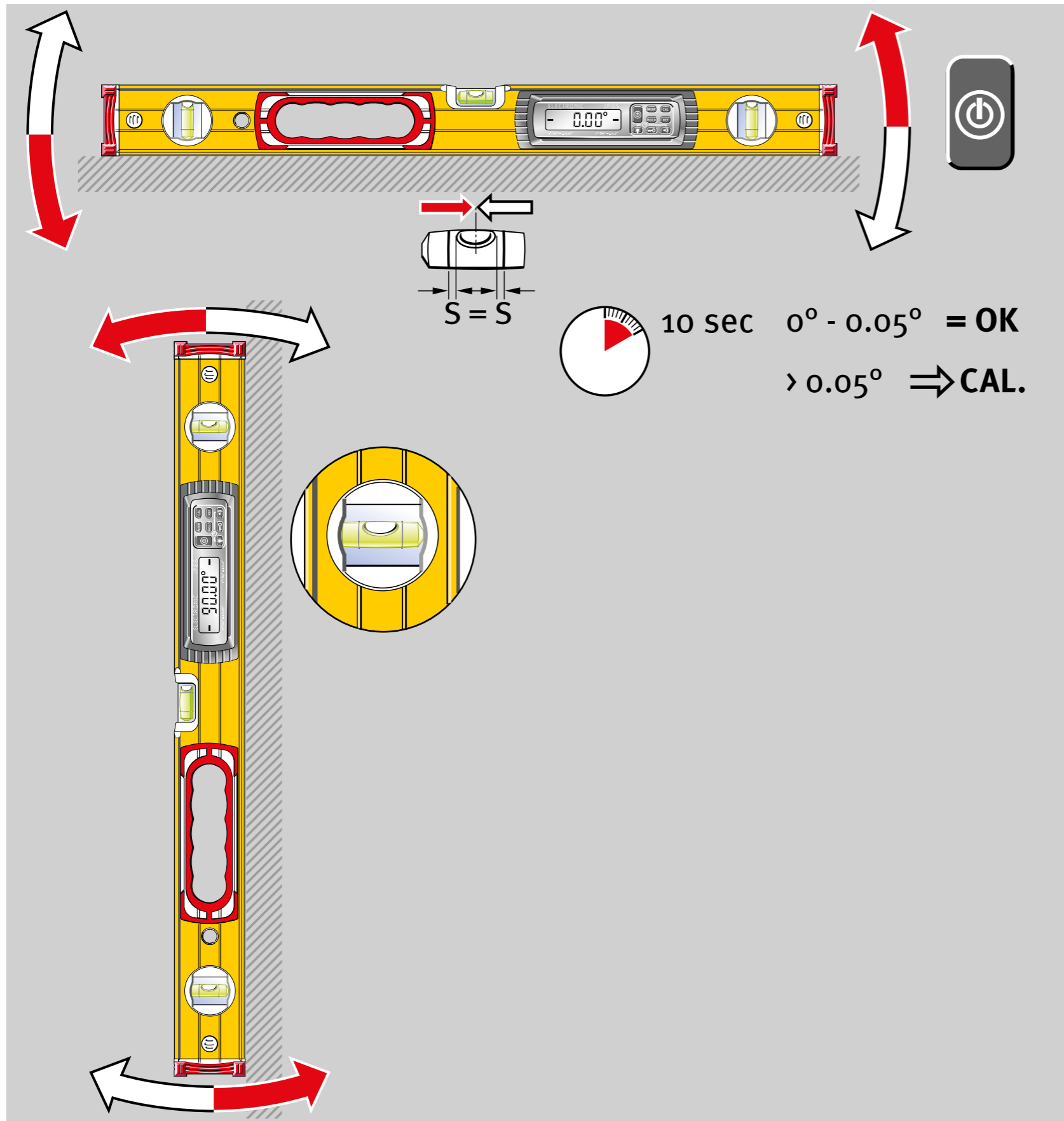

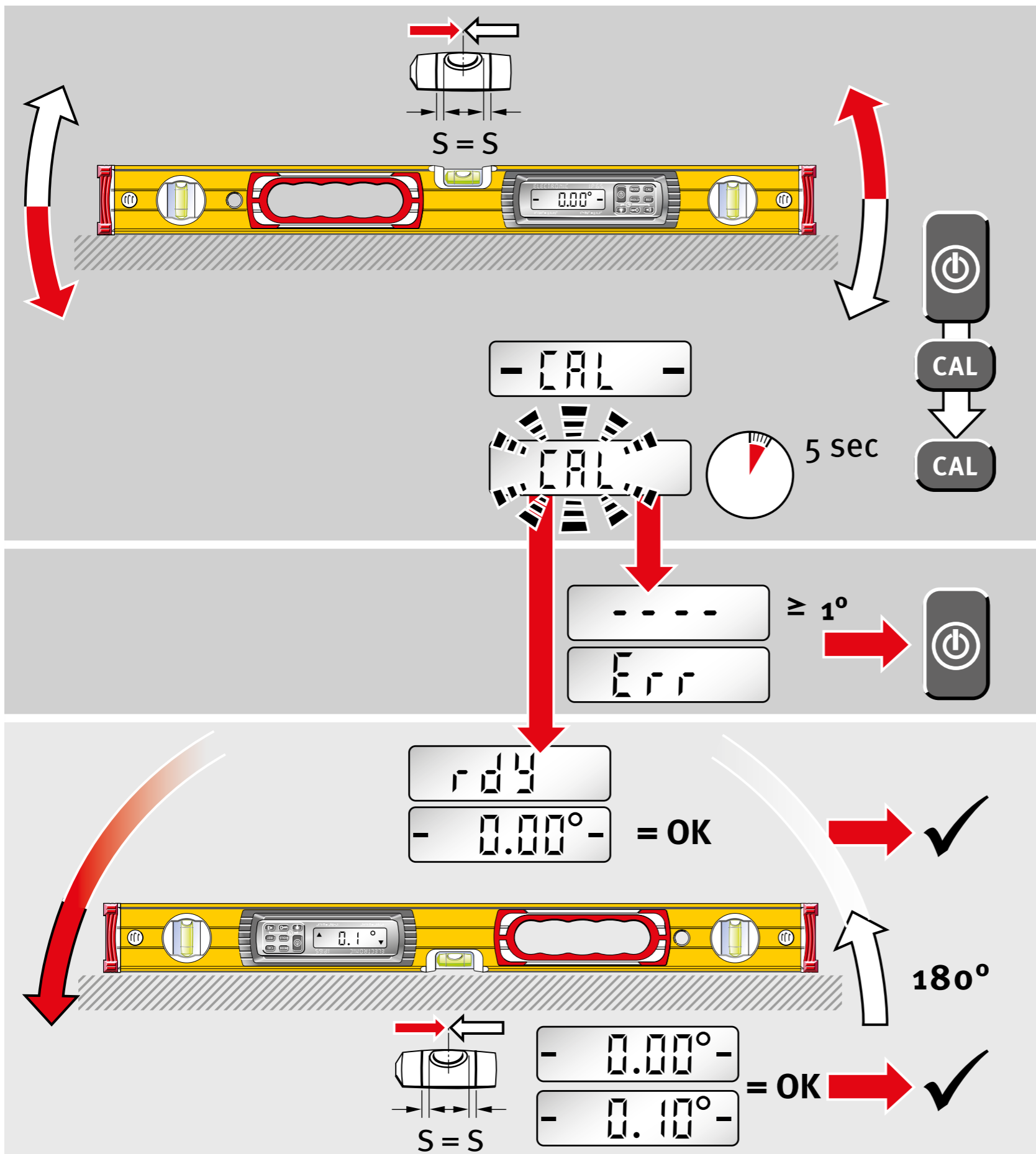

Calibration

1. Switch on the electronic spirit level. Use the vial to accurately align the unit to a wall, for example, until the vial bubble is in the middle between the vial rings.

If mainly used for vertical measurements, the calibration can also be undertaken with the vertical vial.
2. Hold the electronic spirit level in this position and press the CAL button.
The CAL display shows calibration mode.
3. Calibration starts when the CAL button is pressed again.

Newly calibrated value with deviation of $\geq 1^\circ$ from factory setting \Rightarrow Recalibrate spirit level

Vibration during calibration \Rightarrow Recalibrate spirit level

Calibration completed successfully \Rightarrow Spirit level ready

The reverse test checks the calibration.

Angle $\leq 0.1^\circ$ to normal position \Rightarrow Spirit level ready

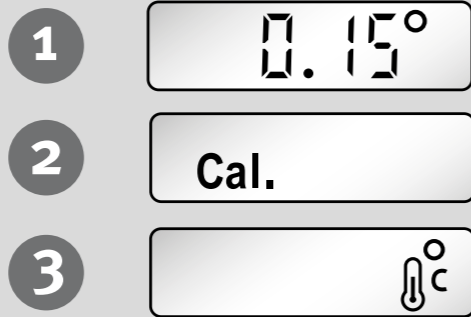

8.3 Adjusting the sensor

Bei folgenden Anzeigen wird eine Sensorjustierung notwendig:

1. The reverse test angle is $\geq 0.1^\circ$ to the normal position
--> too great a deviation.
2. Change in internal reference
3. Change in temperature since last calibration.

The electronic spirit level is calibrated in 4 measuring positions consecutively, turning $90^\circ / 180^\circ$ each time.

A:

All 4 planes are adjusted during the sensor adjustment.

B:

The sensor can only be adjusted if the two black bars appear on the display (in the range of 0° and 90°).

C:

CAL and the planes still to be adjusted flash alternately while the sensor is being adjusted for the respective plane..

D:

Planes that have not been adjusted flash in the display. Successfully adjusted planes are permanently indicated in the display.

A

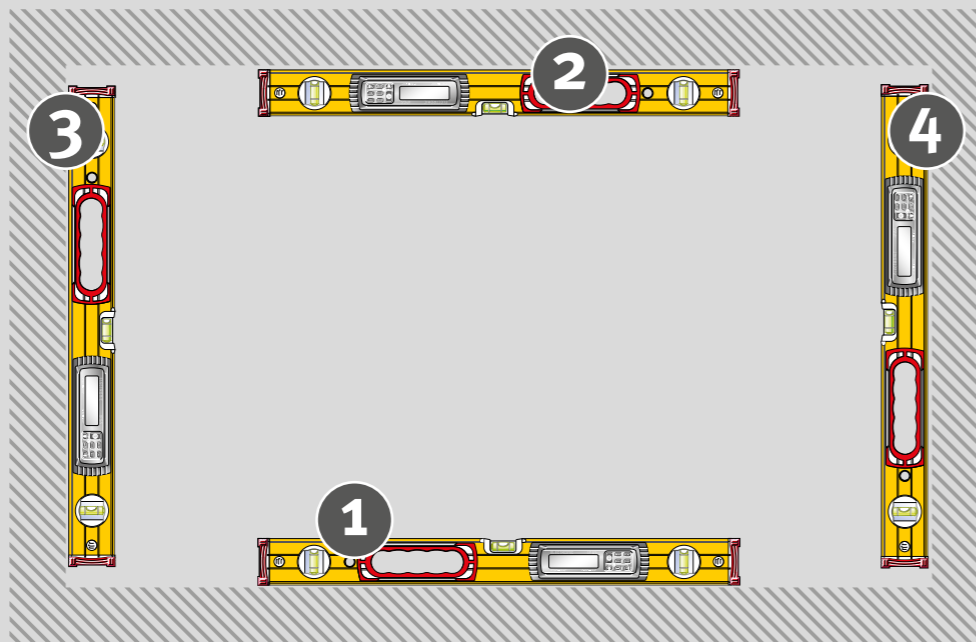

B



C

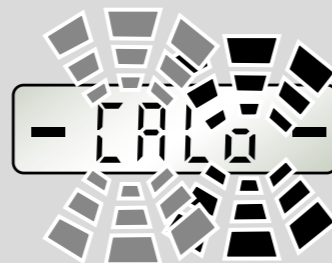

D



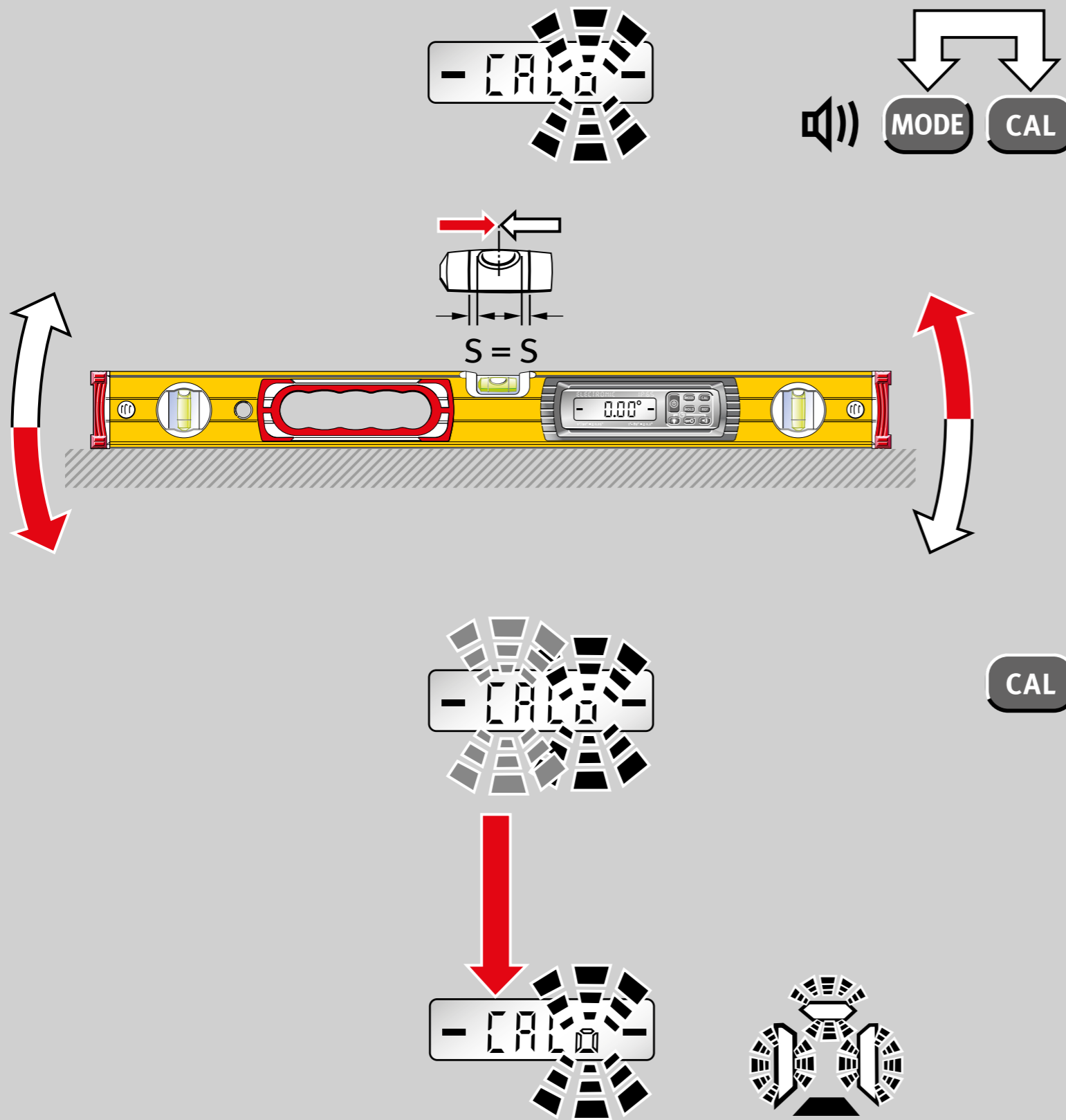

8.3 Adjusting the sensor

Step 1:

Simultaneously press the „MODE“ and „CAL“ buttons. Align the electronic spirit level accurately against a wall and press the CAL button to confirm.



Step 1 must be performed with the vial. This ensures that the spirit level, the horizontal vial and the sensor are synchronised with each other.

Flashing segments indicate the positions still to be calibrated.

Non-flashing segments indicate the positions already calibrated.

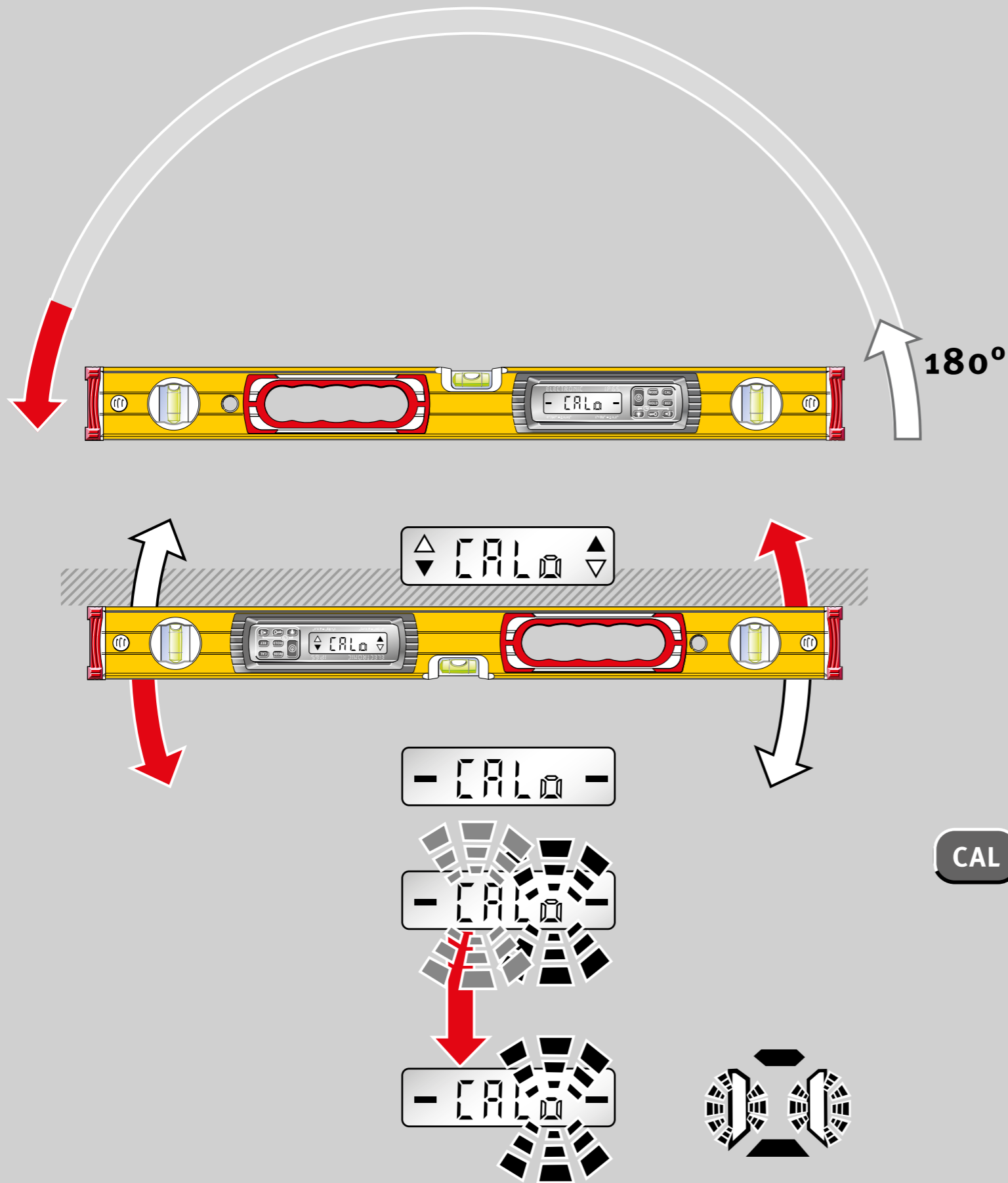

8.3 Adjusting the sensor

Step 2:

The electronic spirit level is turned 180° and aligned using the arrows displayed.

The electronic spirit level is aligned horizontally using the arrows displayed.

The 2 „centre display“ bars indicate the precise position at which the horizontal is reached.

Confirm with the CAL button.

Flashing segments indicate the positions still to be calibrated.

Non-flashing segments indicate the positions already calibrated.

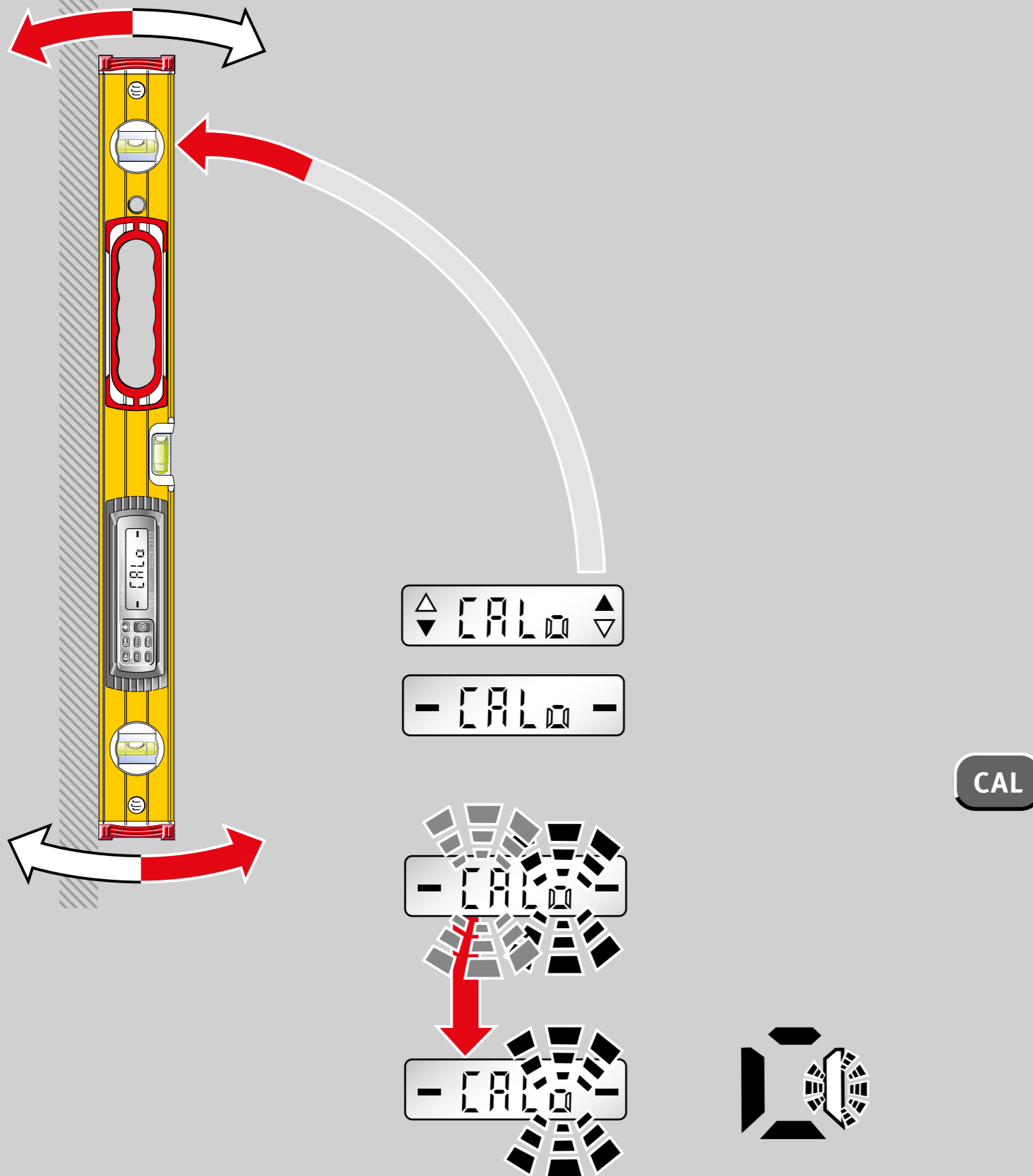

8.3 Adjusting the sensor

Step 3

The electronic spirit level is turned 90° and aligned vertically using the arrows displayed.

The 2 „centre display“ bars indicate the precise position at which the vertical is reached. Confirm with the CAL button.

The flashing segment indicates the position still to be calibrated.

Non-flashing segments indicate the positions already calibrated.

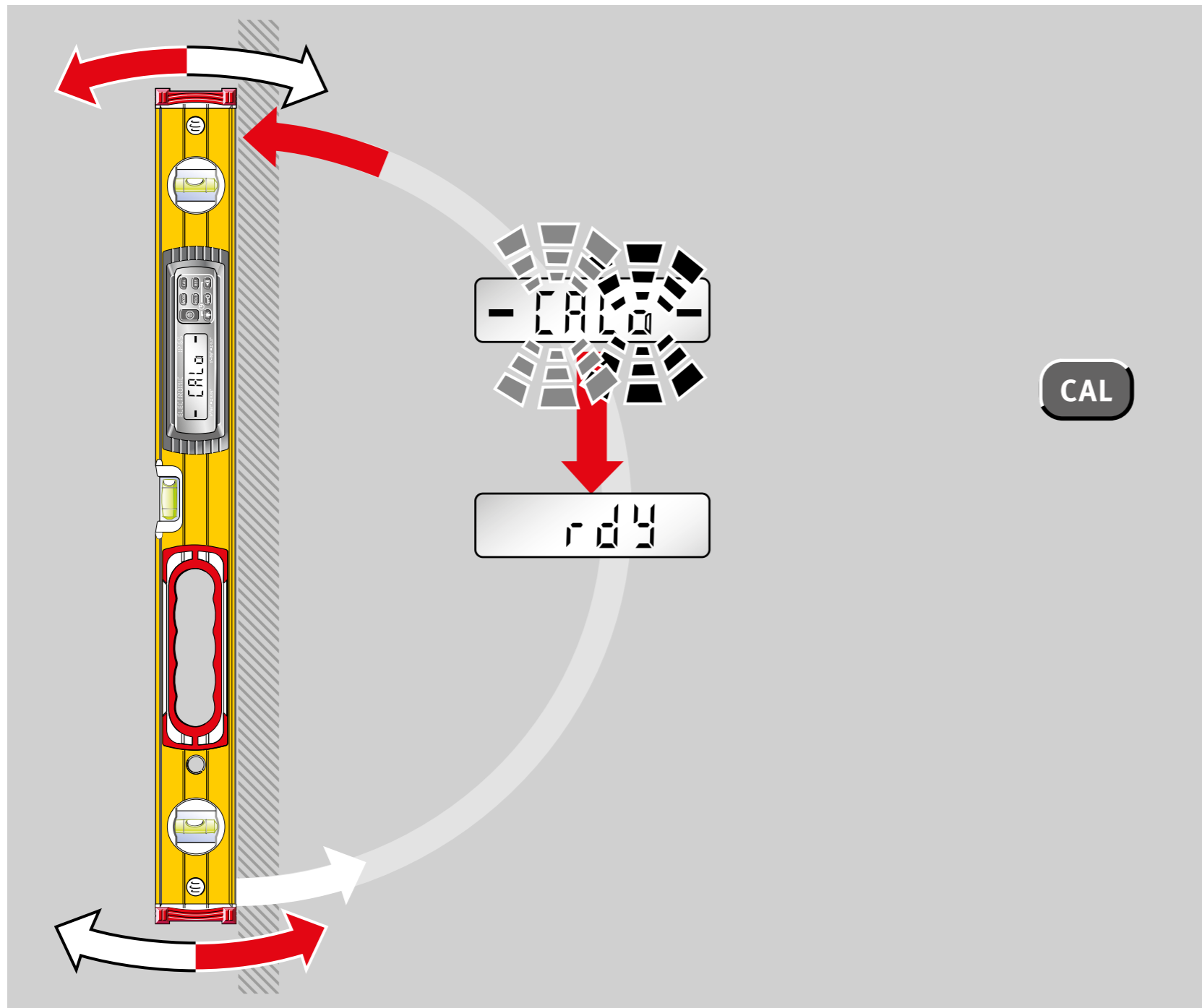

8.3 Adjusting the sensor

Step 4

The electronic spirit level is turned 180° and aligned vertically using the arrows displayed.

The 2 „centre display“ bars indicate the precise position at which the vertical is reached. Confirm with the CAL button.

„rdy“ display:
Calibration in 4 positions successfully completed!



9. Error messages

Display: Cal. /temperature

The sensor must be adjusted if the temperature or Cal. symbols are indicated in the display.

Display: Err

The unit must not be moved or subjected to vibrations during the calibration/sensor adjustment. This can lead to measurement errors.

Display: ----

Unit inclination around longitudinal axis $> 10^\circ$

10. Technical data

Accuracy:

Electronic module

0° / 90° / 180° / 270° :	± 0,05°
In intermediate areas	± 0,2°

Spirit level

in normal position:

0.5 mm / m = 0.029°

in reverse position:

0.5 mm / m = 0.029°

Batteries :

2 x 1.5 V alkaline, Mignon, AA, LR6, MN1500

Operating life:

≥ 150 hours

Operating temperature range:

-10 °C to +50 °C / 14 °F to 122 °F

Storage temperature range:

-20 °C to +65 °C / -4 °F to 149 °F

Protection class:

IP 65

Subject to technical modifications.

Europe
Middle and South America
Australia
Asia
Africa

CE **STABILA Messgeräte**
Gustav Ullrich GmbH

P.O. Box 13 40 / D-76851 Annweiler
Landauer Str. 45 / D-76855 Annweiler

☎ + 49 63 46 309 - 0
✉ info@stabila.de

USA
Canada

STABILA Inc.

332 Industrial Drive
South Elgin, IL 60177

☎ 800-869-7460
✉ custservice@Stabila.com